



SEWAGE SUBMERSIBLE PUMP



LEO LEO GROUP PUMP(ZHEJIANG) CO.,LTD. (Stock code: 002131)

No.1, 3rd Street, East Industry Center, Wenling, Zhejiang, China, 317511
Tel: +86-576-8998 6360 Fax: +86-576-8998 9898 E-mail: export@leogroup.cn www.leogroup.cn

LEO reserves all the right of products modification without prior notification.

www.leogroup.cn

LEO GROUP PUMP(ZHEJIANG) CO.,LTD.

LSWm

CONTENTS

1. Application	2
2. Operation Conditions	2
3. Identification Codes	2
4. Technical Data	3
5. Product Structure & Installation Dimensions	3
6. Safety Precautions	6
7. Maintenance	10
8. Troubleshooting.....	11

8. Troubleshooting



Please shut down the power before repairing the water pump.

Problem	Likely Cause	Solution
Start-up is difficult.	<ol style="list-style-type: none"> 1. Voltage is low; 2. Phase loss (for 3 phase); 3. Impeller is clogged; 4. Voltage drop of the cable is high; 5. Stator winding is damaged. 	<ol style="list-style-type: none"> 1. Adjust voltage to the rated value $\pm 6\%$; 2. Check wires, cable and plug; 3. Clean impeller; 4. Select a proper cable; 5. Return pump to the service center or factory.
Flow is low.	<ol style="list-style-type: none"> 1. Head is too high; 2. Pump inlet is clogged; 3. Impeller is damaged; 4. Immersion depth is not enough; 5. Impeller runs in reverse direction. 	<ol style="list-style-type: none"> 1. Refer to the recommended head range; 2. Clean pump inlet; 3. Replace impeller; 4. Adjust the immersion depth (more than 0.5 m); 5. Exchange any 2 phases of a 3-phase pump.
The pump suddenly stops.	<ol style="list-style-type: none"> 1. Protector is activated or fuse is burnt; 2. Impeller is clogged; 3. Stator winding is damaged. 	<ol style="list-style-type: none"> 1. Check voltage; 2. Clean impeller; 3. Return pump to the service center or factory.

This appliance can be used by children aged from 8 years and above and persons with reduced physical, sensory or mental capabilities or lack of experience and knowledge if they have been given supervision or instruction concerning use of the appliance in a safe way and understand the hazards involved.

Children shall not play with the appliance. Cleaning and user maintenance shall not be made by children without supervision.

Attention!

If the appliance or the supply cord is damaged, it must be repaired by manufacturer, its service agent or qualified person.



Meaning of crossed –out wheeled dustbin:
Do not dispose of electrical appliances as unsorted municipal waste, use separate collection facilities.

Contact you local government for information regarding the collection systems available.

1. Application

LSW series submersible sewage pumps are suitable for buildings, hospitals, residential quarters, municipal engineering, road traffic and construction, factory sewage, sewage treatment, and other occasions. It is used to discharge wastewater, rainwater, and sewage containing solid particles.

2. Operation Conditions

Voltage and frequency: Please refer to the nameplate;

Max.liquid temperature: 40

Liquid pH Value: 4-10

Max.liquid density: 1200kg/m³

The volume ratio of solid impurities in the medium should not exceed 2%.

Protection class: IPX8

It cannot be used for media with strong corrosive fluid and strong abrasive particles.





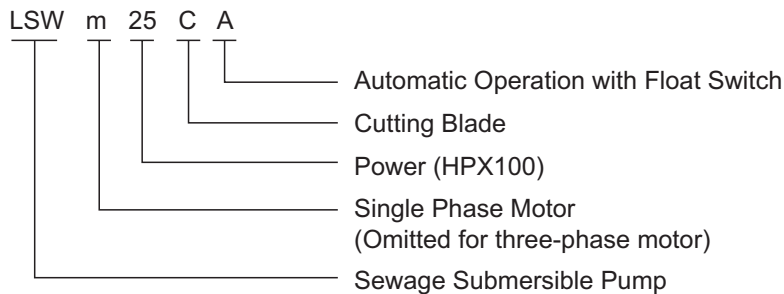



The particle size should not be larger than the largest particle diameter allowed to pass.

3. Identification Codes



7. Maintenance

- 1). Regularly check the insulation resistance between the electric pump winding and the casing. When it is close to the working temperature, the insulation resistance must be greater than 50MΩ (megaohm), otherwise, corresponding measures must be taken to meet the requirements before use.
- 2). The maintenance of the electric pump should be carried out according to the following steps:

 <p>1). Disassemble the pump body.</p>	 <p>2). Unscrew the screw on the impeller and check whether the impeller ring is worn.</p>	 <p>3). Remove the impeller.</p>	 <p>4). Remove the oil chamber cover, pour out the oil, and check whether there is any water stain in the oil.</p>
 <p>5). Remove and replace with a new mechanical seal;</p>	 <p>6). Install the oil chamber cover and fasten with screws.</p>	 <p>7). Carry out the air pressure test on the oil chamber with 0.3MPa air pressure, which lasted 3 minutes, and the pointer should always point to 0.3MPa.</p>	 <p>8). Add oil in the oil chamber, and then screw back the screw (be careful not to leak the O-ring).</p>

- 2). If the pump is not used for a long time, it should be cleaned and placed in a dry and ventilated place.

- 11). The motor is a dry structure, and it is not allowed to fill the motor cavity with oil or water.
- 12). The electric pump oil chamber is filled with oil to ensure that the mechanical seal is effectively lubricated and cooled. In the case of product damage or failure, leakage may occur. In planting, breeding or drinking water, food transportation and processing environments, the leaked oil may cause damage to plants, culture or damage to drinking water, food, etc. produce pollution. The use environment and consequences should be evaluated before choosing this product. In order to confirm whether this product is suitable for use, please ask relevant professionals to confirm if necessary. In case of oil leakage, stop using it immediately and dispose of it properly.
- 13). When the pump is working, if the position of the pump needs to be adjusted or there is an action to contact the pump, the power must be cut off first to prevent accidents.

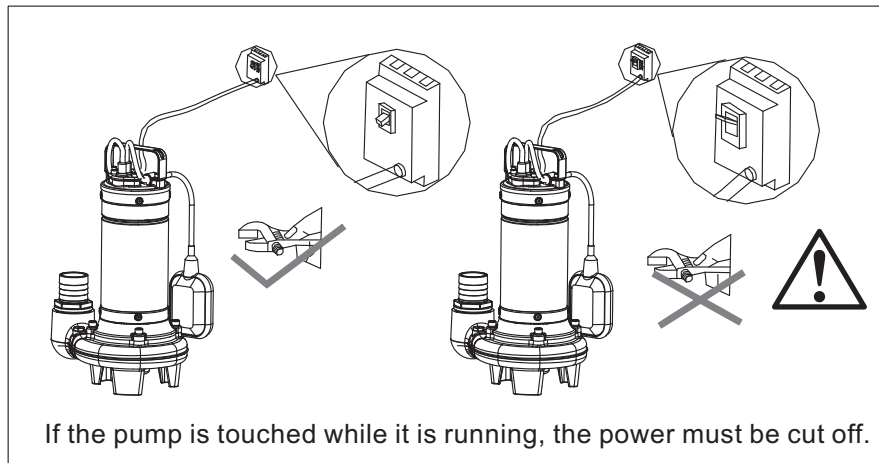

- 14). When the electric pump is working, it is strictly forbidden for the cable connector wire or socket board to submerge in the water. If it is necessary to lengthen the wiring level, the joint should be strictly sealed to prevent leakage of water and electricity.
- 15). After the pump is turned off, the pump can be lifted out of the water when the motor cools down to normal temperature to ensure safety.

4. Technical Data

Model	Power (Kw)	Max. Flow (m³/h)	Max. Head (m)	Max. Diameter of Particle (mm)	Inlet/Outlet
LSWm25A	0.18	11	8	15	G1.5
LSWm30A	0.25	12	9	15	G1.5
LSWm50A	0.37	13	11	20	G1.5
LSWm75A	0.55	16	13.5	25	G2
LSWm100A	0.75	19	17	25	G2
LSWm150A	1.1	26	13.5	30	G2
LSWm200A	1.5	32	19	30	G2
LSWm100CA	0.75	15	13	/	G2
LSWm150CA	1.1	25	14	/	G2
LSWm200CA	1.5	30	17	/	G2

5. Product Structure & Installation Dimensions

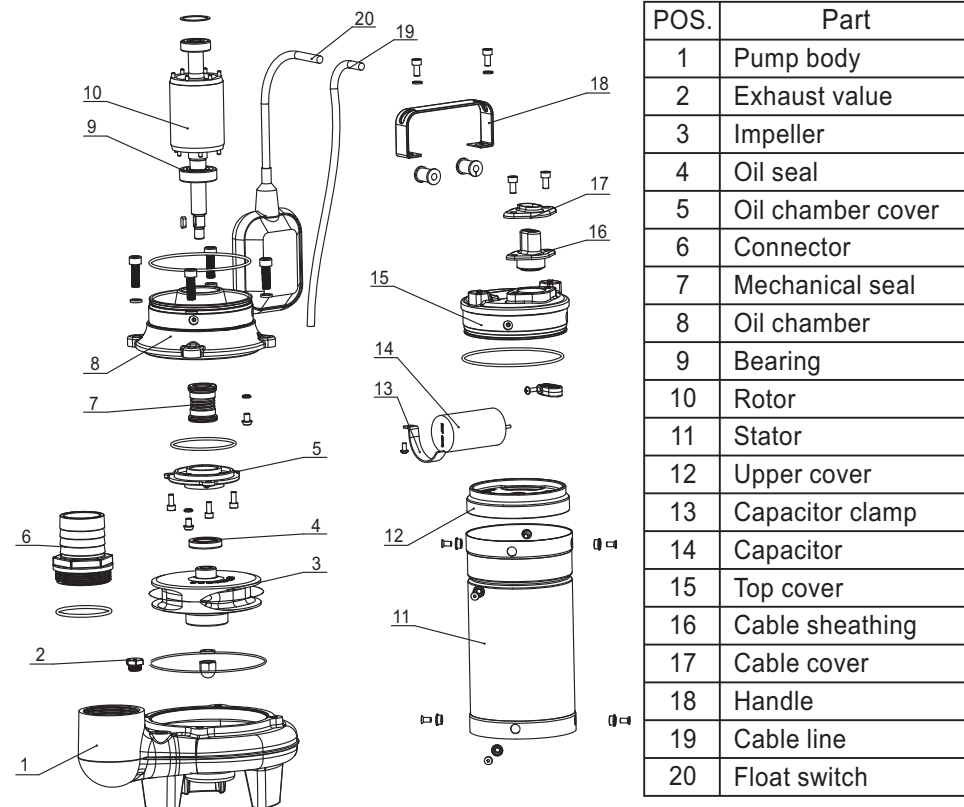

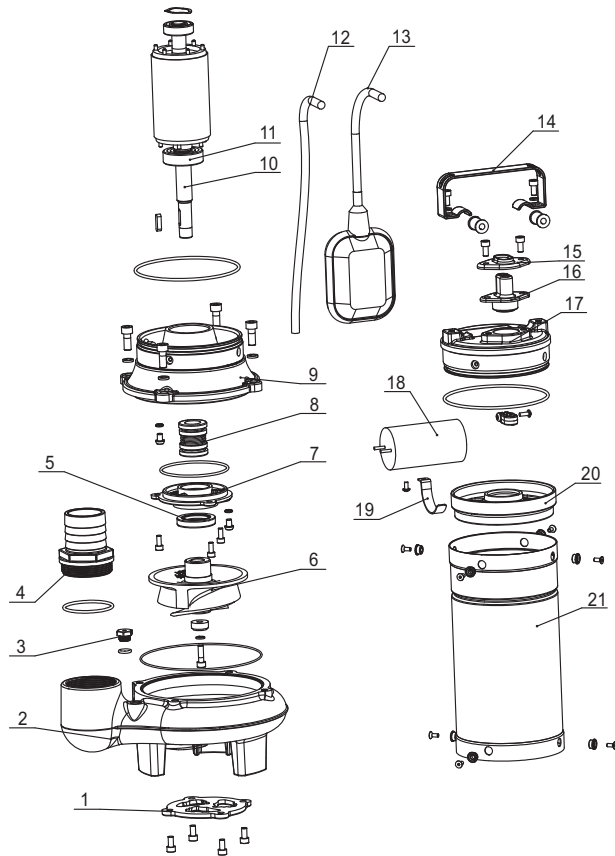

POS.	Part
1	Cutting blade
2	Pump body
3	Exhaust value
4	Connector
5	Oil seal
6	Impeller
7	Oil chamber cover
8	Mechanical seal
9	Oil chamber
10	Rotor
11	Bearing
12	Cable line
13	Float switch
14	Handle
15	Cable cover
16	Cable sheathing
17	Top cover
18	Capacitor
19	Capacitor clamp
20	Upper cover
21	Stator

Power kW	Rated Voltage V		Recommended Cable Length (m)		
			50	100	200
0.25	220	Cross-sectional area of cables mm ²	0.75	1	1.5
0.37			0.75	1	1.5
0.55			1.0	1.5	2.5
0.75			1.0	1.5	2.5
1.1			1.5	2.5	
1.5			2.5	2.5	
2.2			2.5		
0.25	380	Cross-sectional area of cables mm ²	0.75	0.75	0.75
0.37			0.75	0.75	0.75
0.55			0.75	0.75	0.75
0.75			0.75	0.75	0.75
1.1			0.75	0.75	1
2.2			1	1	1
3			1.5	1.5	2.5
4			2.5	2.5	2.5
5.5			2.5	2.5	4
7.5			4	4	

7). When the electric pump is submerged in the water, the diving depth cannot be lower than 0.5m, not more than 5m, and cannot be immersed in the mud. During the work process, the water level should be checked frequently, and the electric pump should not be allowed to work above the water surface.

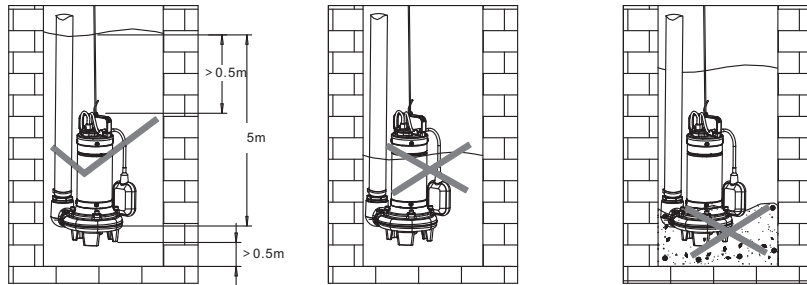

- 8). When the electric pump is working, safety warning signs should be set up at the use site to prevent accidents.
- 9). When the electric pump is in normal operation, the built-in protector will not act. Once the protector is frequently disconnected, the power supply should be cut off, the reason should be checked, and the fault can be eliminated before use.
- 10). If the ground is far from the power supply, please refer to the table below to thicken the cable according to the distance.

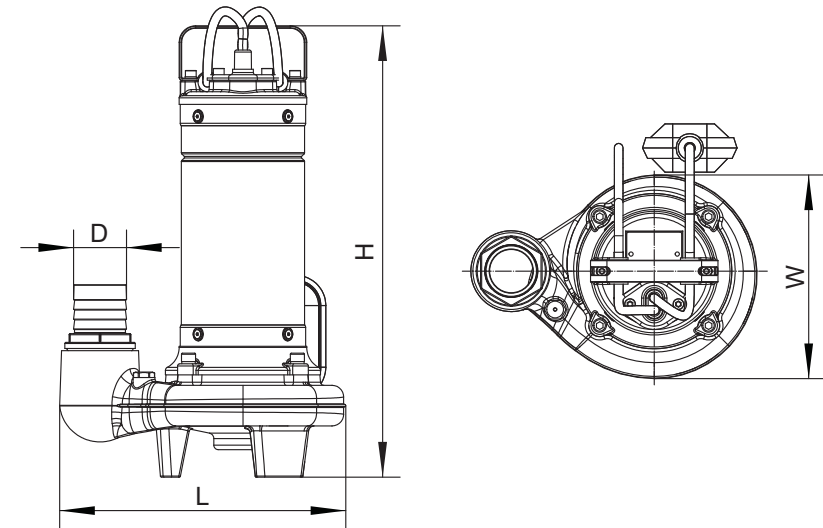

Model	D mm	L mm	W mm	H mm
LSWm25A	G1.5/40	221	158	362
LSWm30A	G1.5/40	221	158	362
LSWm50A	G1.5/40	221	158	372
LSWm75A	G2/50	260	185	410
LSWm100A	G2/50	260	185	410
LSWm150A	G2/50	269	186	426
LSWm200A	G2/50	269	186	426
LSWm100CA	G2/50	245	165	416
LSWm150CA	G2/50	269	186	426
LSWm200CA	G2/50	269	186	426

6. Safety Precautions



Proficient in this manual and have the professional qualifications of staff to install and maintain the product.



Unless the power is off, or else do not junction box wiring work.
Pump should be grounded to prevent leakage, and should be equipped with leakage protection switch.
If the pump outdoor use, you must use an extension cord for outdoor use rubber cable.

- 1). Before installation and use, comprehensively check whether the electric pump is damaged during transportation and storage, such as whether the cables are intact. If there is any damage, please ask professionals to repair or replace it before use.
- 2). Before the pump runs, check that the insulation resistance should be greater than $50M\Omega$.

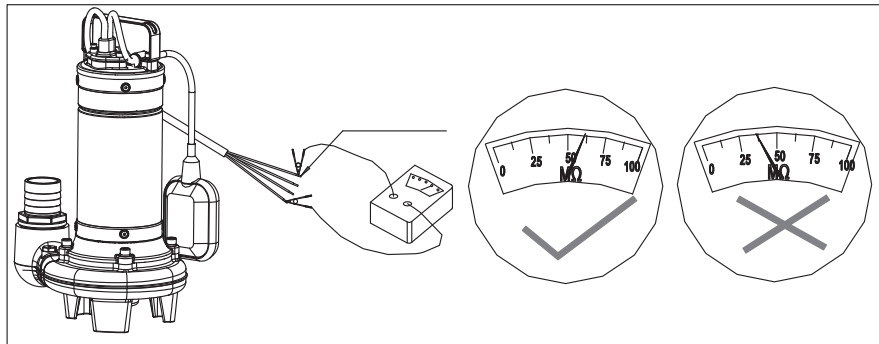

- 3). When wiring, the electric pump should be properly installed with leakage protection device.
- 4). Note: Before the three-phase submersible pump is launched, it is necessary to confirm the direction of the motor. If the motor is found to be reversed, the power supply should be cut off immediately, and any two cables of the three-phase pump should be exchanged.

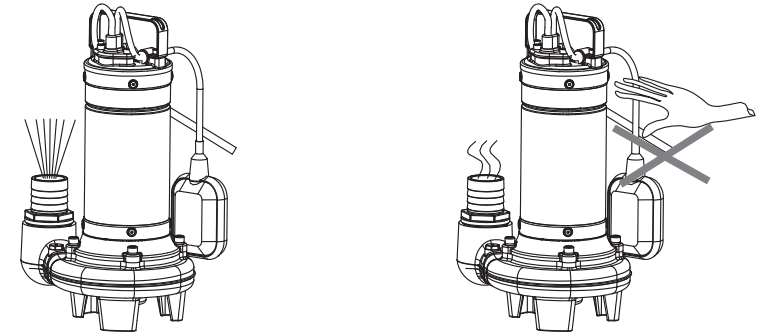

- a. After the power is turned on, the wind is very strong at the water outlet.
- b. The direction of the motor is reversed. After the power is turned on, the wind at the water outlet is very small or even no wind.
- c. Do not touch the pump after power on!

- 5). When connecting the hose to the water outlet, it can be fastened with iron wire or clamp;
- 6). When the water pump is moving, it is strictly prohibited to pull the cable.

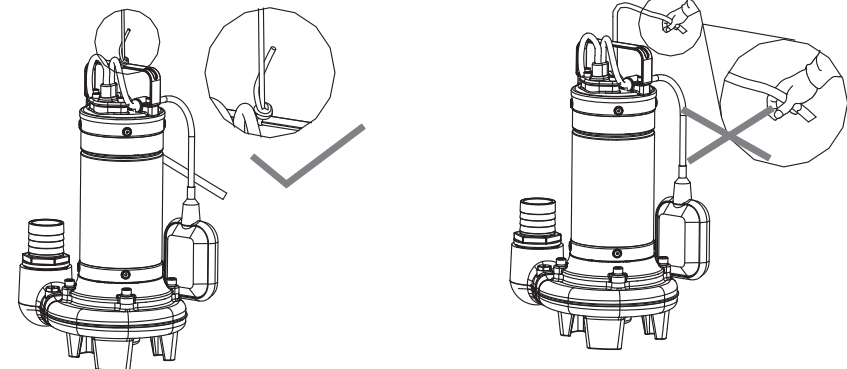

- a. The handle should be tied with a rope before the electric pump is launched.
- b. During the transportation of the electric pump, do not lift the cable and float switch as a sling.